



Operating instructions

Extender

Type: Liquidtool Extender
Product number: LTE-1-01-XXXXXX
Year of manufacture: 2023



Follow these instructions for proper and safe use.
Keep for future reference.

TABLE OF CONTENTS

Table of contents	3
Purpose of the operating instructions.....	5
Orientation in the operating instructions	5
1 Identification	7
1.1 Product labeling	7
1.2 Manufacturer's data.....	7
1.3 Nameplate.....	8
1.4 Declaration of conformity.....	9
2 Basic safety instructions	10
2.1 Operator's duty of care.....	10
2.2 General occupational safety.....	10
2.2.1 Personnel qualification.....	10
2.2.2 Authorized personnel	11
2.3 Residual hazards	11
2.3.1 Hazards due to electrical energy.....	11
2.3.2 Hazards due to magnetism	11
2.3.3 Hazards due to leakage and hose lines	12
2.3.4 Hazards due to cooling lubricant (KSS)	13
2.4 Safety instructions of the extender	14
2.5 Emergency information	14
3 Description, structure and function.....	15
3.1 Intended use	15
3.2 Reasonably foreseeable misapplication	15
3.3 Conversions and modifications	15
3.4 Technical data.....	15
3.5 Location requirements.....	16
3.6 Structure.....	16
3.7 Function and system description.....	17
3.8 LED status light	17
3.9 Interfaces	18
4 Transport, installation and storage	19
4.1 Introductory notes on safety	19
4.2 Packing	19
4.3 Transport.....	19
4.4 Delivery	20
4.4.1 Scope of delivery	20
4.4.2 Inspection for transport damage	20
4.5 Download app	21
4.6 Storage.....	21
5 Commissioning.....	22
5.1 Introductory notes on safety	22
5.2 Installation.....	22
5.3 Notes on connecting the extender.....	23
5.4 Connection	24
6 Operation.....	31
6.1 Introductory notes on safety	31



6.2	Switch on extender.....	31
6.3	Switch off extender.....	31
6.4	Operation	31
7	Decommissioning.....	32
7.1	Introductory notes on safety	32
7.2	Dismantling	32
7.3	Cleaning	35
8	Maintenance and repair.....	35
8.1	Troubleshooting	35
9	Waste disposal.....	36
9.1	Introductory notes on safety	36
9.2	Dismantling	36
9.3	Proper and environmentally compatible disposal	36
9.4	Disposal points.....	36

PURPOSE OF THE OPERATING INSTRUCTIONS

Before operating the Extender for the first time or when you are assigned to do other work on the Extender, you must read the Operating Instructions.

The use and handling of the extender described below is not self-evident and is explained in detail in the accompanying technical documentation.

Pay particular attention to chapter "2 Basic safety instructions".

Operating instructions

The operating instructions will help you to use the Extender properly, effectively and safely in accordance with its intended purpose. Therefore, read the following chapters carefully and attentively. If necessary, always refer to the information that is important to you.

Residual risks

The operating instructions inform and warn you of residual risks against which risk reduction by design and protective measures is not or not completely effective.

ORIENTATION IN THE OPERATING INSTRUCTIONS

Representation of general information symbols

These operating instructions contain the following general information symbols to guide you, the reader, through the operating instructions and to provide you with important information.

Pictogram	Meaning
	Caution possible property damage This pictogram indicates that material damage to the extender may occur during an action if the action specifications are not correctly observed and performed.
	Important information This pictogram indicates important additional information that includes a warning of a hazard.
	Personnel qualification This pictogram indicates which personnel (target group) are allowed to perform the actions in the respective chapter.
	Instruction for action This pictogram indicates an instruction for action and always precedes an active action to be performed by the user.

Tab. 1: General pictograms and their meaning

Possible symbols in an instruction manual

Warning symbols warn of danger spots, risks and obstacles.



Danger point warning



Magnetic field warning



Warning of crushing hazard



Warning of trip hazards



Warning of flammable substances



Slip hazard warning



Warning against substances harmful to health



Environmental damage warning

Commandment symbols are used for accident prevention at the workplace



General bid symbol



Wear safety shoes



Wear protective gloves



Wear appropriate work clothes



Wear safety goggles



Read instruction

Prohibition symbols contribute to more safety.



General prohibition symbol



Prohibition for persons with pacemaker



Prohibition of food and beverages in the workplace prohibited



Prohibition of open fire and ignition sources

1 IDENTIFICATION

1.1 Product labeling

Extender

Product number: LTE-1-01-XXXXXX

Year of manufacture: 2023

1.2 Manufacturer information

Headquarters	Liquidtool Systems AG
	Winterseistrasse 22
	3415 Hasle-Rüegsau
	Switzerland
Email:	support@liquidtool.com
Internet:	www.liquidtool.com

Tab. 2: Manufacturer's data

1.3

Nameplate

The extender is clearly identified by the nameplate and the product information on the product.
The nameplate of the extender is located on the bottom of the extender.

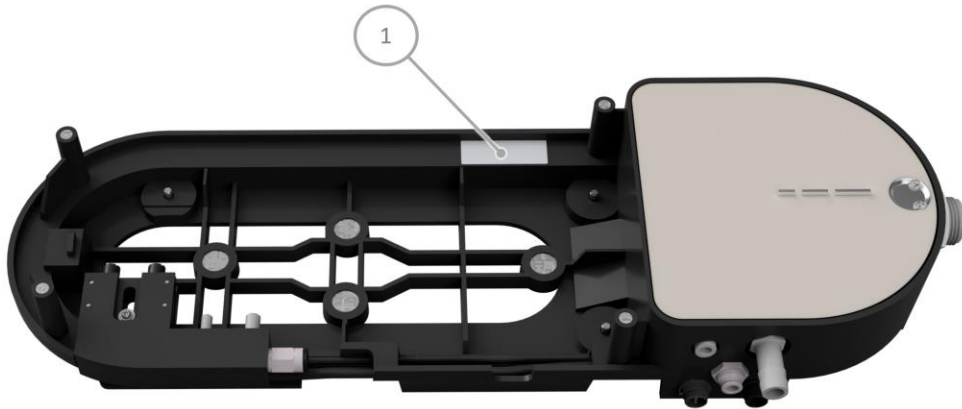

Fig. 1: Mounting location

- 1 Nameplate



Fig. 2: Nameplate

- 1 Company address
- 2 For EU member states only: Disposal notice for electrical appliances
- 3 Year of manufacture indication

1.4 Declaration of Conformity

EC Declaration of Conformity

The manufacturer / distributor
Liquidtool Systems AG
Winterseistrasse 22
3415 Hasle-Rüegsau
Switzerland

hereby declares that the following product

Product name: Fluid Level Sensor
Model name: Extender
Type designation: Liquidtool Extender
Serial number: LTE-1-00-XXXXXX
Year of manufacture: 2023
Description:
Sensor for measuring and monitoring the level of a cooling lubricant tank

complies with all relevant provisions of the applied legal regulations (hereinafter) - including their amendments in force at the time of the declaration. The sole responsibility for issuing this declaration of conformity lies with the manufacturer. This declaration refers only to the machine in the condition in which it was placed on the market; parts added and/or interventions made subsequently by the end user are not taken into account.

The following legislation has been applied:
Machinery Directive 2006/42/EG
Radio Equipment Directive 2014/53/EU
RoHS Directive 2011/65/EU

The protection goals of the following other legal regulations were met:
Low Voltage Directive 2014/35/EU

The following harmonized standards have been applied:
EN 60204-1:2006/AC:2010 Safety of machinery - Electrical equipment of machines - Part 1: General requirements (IEC 60204-1:2005 (Modified))
EN ISO 12100:2010 Safety of machinery - General principles for design - Risk assessment and risk reduction (ISO 12100:2010)
EN ISO 19353:2016 Safety of machinery - Fire prevention and protection (ISO 19353:2015)
EN ISO 20607:2019 Safety of machinery - instruction handbooks - General principles for design (ISO 20607:2019)

Name and address of the person authorized to compile the technical documentation:
Manfred Schneeberger
Liquid Tool Systems AG
Winterseistrasse 22
3415 Hasle-Rüegsau
Switzerland

Location: Hasle-Rüegsau
Date : 05.05.2023

(Signature)
Head of Research and Development



Fig. 3: Declaration of conformity

2 BASIC SAFETY INSTRUCTIONS

2.1 Duty of care of the operator

Technical condition of the extender

The following requirements are placed on the technical condition of the extender and must be ensured by the operator:

- The extender may only be used as intended
- The extender must always be checked for their proper technical condition before being switched on
- The safety devices must be checked regularly for proper functioning
- The safety and warning notices attached to the extender must not be removed and must be regularly checked for legibility and replaced if necessary
- No unauthorized conversions, manipulations and modifications may be made to the extender
- The operating instructions must always be available in legible condition and complete at the place of use of the Extender, this also applies to the instructions from suppliers.

2.2 General occupational safety

2.2.1 Personnel qualification



Important information about personnel qualification

All activities on the Extender may only be carried out by instructed, trained and authorized persons.

⚠ WARNING	
	<p>Danger due to insufficient personnel qualifications</p> <p>There is a risk of serious injury and considerable damage to property if unqualified personnel are in the danger zone or carry out work on the Extender.</p> <ul style="list-style-type: none"> ➤ Operating personnel must meet the specified qualification. ➤ Unqualified personnel must be kept away from the hazardous area.

Trained, instructed operating personnel

A trained/instructed person is a person who has been instructed and, if necessary, trained about the tasks assigned to him/her and the possible dangers in case of improper behavior. He/she has also been instructed about the necessary protective equipment and protective measures. Personnel to be trained, instructed or undergoing general training may only work under the constant supervision of an experienced person. The personnel has read and understood the operating instructions.



Specialist A specialist is defined as a person who has successfully completed vocational training. The specialist must also have knowledge of the relevant standards and regulations. They must be able to assess the work assigned to them and, on the basis of their professional training and work experience, must be able to recognize and avoid potential hazards on their own.

Electrician The electrician is a person in the sense of a specialist with special knowledge in the field of electrical engineering (training in a recognized training profession as a journeyman/skilled worker, master craftsman, industrial foreman, state-certified technician, graduate engineer, bachelor or master).

2.2.2 Authorized personnel

Life phase/chapter	Personnel qualification
Transport, installation and storage	<ul style="list-style-type: none"> Trained, instructed operating personnel
Commissioning	<ul style="list-style-type: none"> Trained, instructed operating personnel Specialist Qualified electrician for work on electrical systems or equipment
Operation	<ul style="list-style-type: none"> Trained, instructed operating personnel
Decommissioning	<ul style="list-style-type: none"> Trained, instructed operating personnel Specialist Qualified electrician for work on electrical systems or equipment
Service and maintenance	<ul style="list-style-type: none"> Trained, instructed operating personnel Specialist Qualified electrician for work on electrical systems or equipment
Disposal	<ul style="list-style-type: none"> Trained, instructed operating personnel Specialist Qualified electrician for work on electrical systems or equipment
Troubleshooting	<ul style="list-style-type: none"> Specialist Qualified electrician for work on electrical systems or equipment

Tab. 3: Authorized personnel

Instruction The personnel working on the extender must be regularly trained and instructed by the operator.

2.3 Residual hazards

2.3.1 Hazards due to electrical energy

The extender is connected to the power supply via a 24 volt power supply unit. When connecting the power supply to the extender, check that the cable is seated correctly.

Before maintenance work or disassembly, disconnect the power plug and thus disconnect the extender from the power supply.

The electrical equipment of the Extender must be checked at regular intervals. Defects, such as loose connections, rubbed or scorched cables, must be rectified immediately by a qualified electrician.

The Extender must be switched off immediately in the event of faults in the electrical power supply.

2.3.2 Magnetism hazards

Hazards due to strong magnets

The extender is attached to surfaces by powerful magnets. These magnets cause electromagnetic fields that can affect pacemakers and similar devices. This can lead to malfunctions in pacemakers. The electromagnetic field affects devices in the immediate vicinity,

the perimeter is about 0.5 meters around the extender. Persons with pacemakers should not stay in this field.

⚠ WARNING	
	<p>Danger from strong magnets</p> <p>The magnets cause strong, electromagnetic fields that can affect and interfere with electronic devices such as pacemakers. Malfunctioning pacemakers can cause death or serious injury to affected individuals.</p> <ul style="list-style-type: none"> ➤ Persons with pacemakers must not be in the vicinity of the extender. ➤ Persons with pacemakers must not perform any activities with the extender. ➤ Regularly check this warning notice on the extender or on the machine tool. Replace damaged warning notices immediately.

The hazard exists even when the extender is switched off, the magnets are always active. Persons with pacemakers must therefore not carry out any activities with the extender (neither transport, commissioning, disposal or maintenance and servicing).

In addition, regularly check the warning signs attached to the machine tool for damage. Only these pictograms can warn and protect uninvolved third parties from the magnets. For this purpose, comply with the information in the maintenance plan.

Risk of crushing due to magnets

The extender is attached to surfaces such as machine housings by strong magnets. During assembly, the magnetic effect can instantly pull the extender to the surface. If the fitter does not pay attention to his fingers, they can be crushed. This can result in slight bruising of individual fingers or fingertips. The extender has recessed grips on the housing to protect against crushing. Together with appropriate care, the extender can be mounted without risk.

Falling extender

The extender is attached to surfaces by means of magnets. If the magnetic adhesion of the surface is too low or non-existent, the extender may fall down. Falling down can crush the installer's feet. If the extender falls to the floor, it can be damaged.

Test the magnetic effect of the surface by carefully moving the extender towards it. Observe the magnetic effect and hold the extender by the recessed grips to prevent your fingers from being crushed. Then observe the extender for a short time to see if it moves and threatens to fall off. If the extender moves, a different surface must be selected for attachment.

2.3.3 Hazards due to leakage and hose lines

Leakage and defective hose lines

The extender is connected to a cooling lubricant tank via hose lines. If these lines are not laid properly or if damaged lines are used, this will lead to leaks and cooling lubricant will escape. Escaping cooling lubricant can cause injuries (e.g. by slipping). Therefore, lay the hose lines carefully and without tripping. Before commissioning, check the assembly of the hose lines on the cooling lubricant container and extender. Comply with the specifications in the maintenance plan for regular checks.





Risk of tripping due to cables

The extender is connected to the tank of the cooling lubricant with hose lines. These hose lines must be laid carefully to prevent the risk of tripping. Persons who trip over hose lines can fall and injure themselves. In addition, the lines or the connections on the extender or on the tank can be damaged and cooling lubricant can escape in an uncontrolled manner.

2.3.4 Hazards due to cooling lubricant (KSS)

Hazard due to cooling lubricants (KSS)

Depending on the cooling lubricant used, there may be various hazards and risks. Therefore, be sure to read the data sheet of the cooling lubricant!

⚠ WARNING	
    	<p>Damage to health due to cooling lubricant</p> <p>Direct contact of cooling lubricant with the skin can lead to illness and damage to health.</p> <p>Direct eye contact with cooling lubricant can cause severe irritation of the eyes.</p> <p>Inhalation of the vapors or aerosols may cause irritation and respiratory diseases.</p> <p>Escaping and/or splashing cooling lubricant can contaminate food or drink.</p> <ul style="list-style-type: none"> ➤ Observe the data sheet of the cooling lubricant. ➤ Wear protective gloves. ➤ Wear protective goggles. ➤ During maintenance, servicing, cleaning and disposal, note that residues of the cooling lubricant are present in the lines and in the unit even after it has been switched off. ➤ Eating and drinking in the vicinity of cooling lubricant is prohibited! ➤ Contact a doctor immediately if you experience any discomfort.

Spilled cooling lubricant must be wiped up and disposed of immediately. There is a danger of slipping! Persons could slip in it and injure themselves. Therefore, also check the lines regularly for leaks (see maintenance schedule).

NOTE	
	<p>Environmental damage due to leaking cooling lubricant</p> <p>Escaping cooling lubricant damages the environment and can be the trigger for further hazards.</p> <ul style="list-style-type: none"> ➤ Observe the data sheet of the cooling lubricant. ➤ Regularly check pipelines for leaks. ➤ Remedy any leaks discovered immediately. ➤ Dispose of cooling lubricants in accordance with regulations. ➤ During maintenance, servicing, cleaning and disposal, note that residues of the cooling lubricant are present in the lines and in the unit even after it has been switched off. ➤ Notify the appropriate environmental agency in the event of large spills.

2.4 Safety instructions of the extender

The extender is supplied with several pictograms and warnings as stickers. Due to the small size of the product, these cannot be attached to the extender. During assembly, they must instead be affixed in the vicinity of the extender, e.g. on the housing of the machine tool. These stickers must be checked regularly. Damaged stickers must be replaced immediately.



Fig. 4: Safety instructions on the machine tool (example)

1	<p>⚠️ WARNUNG</p> <p>Gesundheitsschäden durch Kühlschmierstoff Der direkte Kontakt von Kühlschmierstoff mit der Haut kann zu Erkrankungen und gesundheitlichen Schäden führen. Direkter Augenkontakt mit Kühlschmierstoff kann zu heftigen Reizungen der Augen führen. Das Einatmen der Dämpfe oder Aerosole kann zu Reizungen und Erkrankungen der Atemwege führen. Ausströmer und/oder spritzender Kühlschmierstoff kann Essen oder Trinken kontaminieren.</p> <ul style="list-style-type: none"> ➤ Beachten Sie das Datenblatt des Kühlschmierstoffes. ➤ Tragen Sie Schutzhandschuhe. ➤ Tragen Sie eine Schutzbrille. ➤ Beachten Sie während der Wartung, Instandhaltung, Reinigung und Entsorgung, dass Rückstände des Kühlschmierstoffes in den Leitungen und im Gestell auch nach Abschaltung vorhanden sind. ➤ Essen und Trinken in der Nähe von Kühlschmierstoff sind verboten! ➤ Kontaktieren Sie bei Beschwerden sofort einen Arzt. 	3	<p>⚠️ VORSICHT</p> <p>Quetschgefahr durch starke Magnetkräfte Die Magnete des Sensors sind stark und werden schnell an die metallische Oberfläche gezogen. Gelangen Finger zwischen die Magnete und die metallische Oberfläche, können sie gequetscht werden.</p> <ul style="list-style-type: none"> ➤ Halten Sie den Sensor so, dass Ihre Finger in der Griffmulde sind.
2	<p>⚠️ WARNUNG</p> <p>Gefährdung durch starke Magnete Die Magnete verursachen starke, elektromagnetische Felder, die elektronische Geräte wie Herzschrittmacher beeinflussen und stören können. Fehlfunktionen von Herzschrittmachern können bei den betroffenen Personen zu Tod oder schweren Verletzungen führen.</p> <ul style="list-style-type: none"> ➤ Personen mit Herzschrittmachern dürfen sich nicht in der Nähe der LTS SensorBox aufhalten. ➤ Personen mit Herzschrittmachern dürfen keine Tätigkeiten mit der LTS SensorBox durchführen. ➤ Kontrollieren Sie regelmäßig das Warnhinweis auf dem Produkt. Ersetzen Sie beschädigte Warnhinweise umgehend. 		

2.5 Emergency information

Behavior in an emergency

In the event of an emergency on the Extender, it must be put out of operation by disconnecting the power plug. It must be checked whether there are any injured persons.

SAFETY NOTE	
	<p>In case of malfunction or emergency, immediately pull out the mains plug!</p> <p>This disconnects the extender from the power supply and thus shuts it down immediately.</p>



Important information for your safety

You are responsible!

In any case, the safety instructions in chapter "2 Basic safety instructions" and the locally applicable safety regulations must be observed and complied with.



Important information in the data sheet of the cooling lubricant

There are different cooling lubricants which can have different effects on health. In case of emergencies, observe the data sheet of the cooling lubricant!

3 DESCRIPTION, STRUCTURE AND FUNCTION

3.1 Intended use

The extender may only be used in combination with the Liquidtool sensor. It is used to extend the functionality of the sensor and thus, together with the SmalrFiller, enables the automatic filling of a machine tool with cooling lubricant. The cooling lubricant must be water emulsifiable. For the measurement, the extender requires access to the cooling lubricant tank of a machine tool. The access is established via the hose lines. The app belonging to the extender then collects the determined data.

The extender may only be used if:

- This is in technically perfect condition
- The personnel has the necessary safety and hazard awareness
- The instructions in the operating manual are followed

3.2 Reasonably foreseeable misapplication

The Extender is not intended for any purpose other than the intended use listed here.

In principle, any use other than the intended use is considered improper use. This means that safe operation is no longer guaranteed. The operator, and not the manufacturer, is responsible for all personal injury and damage to property resulting from improper use.

Foreseeable misapplication also includes:

- Improper mounting, commissioning, operation and maintenance of the Extender
- Operating the extender in a faulty state
- Operating the extender without protective coverings
- Setting up or operating the Extender in potentially explosive atmospheres
- Use of operating materials that are not approved by the manufacturer

3.3 Conversions and modifications

For safety reasons, conversions and modifications to the extender are only permitted after consultation with the manufacturer.

The use of non-original spare parts may invalidate liability for any resulting consequences. Therefore, always use only the specified spare parts, this applies in particular to safety-relevant components.

3.4 Technical data

Mass and weight

	Value	Unit
Length/Depth	525	mm
Wide	200	mm
Height	78	mm
Weight	4.3	kg

Tab. 4: Mass and weight

Connected loads and power - electricity

	Value	Unit
Voltage	24	VDC
Power	max. 2.5	A
Mains connection	External power supply with 100-240V / 50-60Hz AC 5 connection adapters (ILC type A, C, G, I)	
Protection class	Dust and splash water protected	

Tab. 5: Connected loads and power - electricity

Interfaces

Communication / Interfaces
RS 485

Tab. 6: Interfaces

Emission values

	Value
Sound power level	<75 dB(A) A-weighted equivalent continuous sound pressure level is below 70 dB(A)

Tab. 7: Emission values

3.5 Location requirements

To ensure trouble-free operation of the extender, the following location and installation conditions must be met.

Temperature

The ambient temperature must be between +5 °C and +40 °C to ensure smooth operation. The environment must be frost-free, dry and protected against corrosion.

3.6 Structure

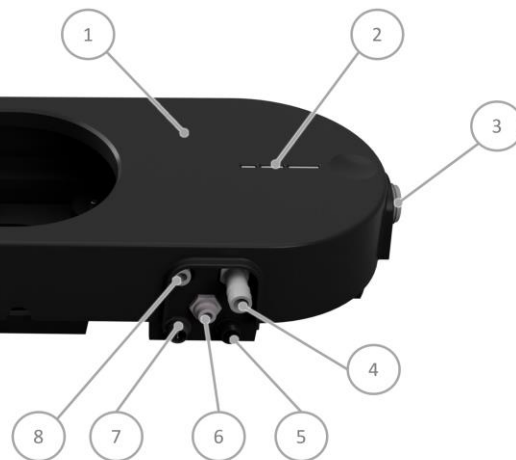

Fig. 5: Structure of the extender (bottom diagonal view)

- | | |
|-------------------------|---|
| 1 Housing | 5 Connection ultrasonic sensor |
| 2 Status LED | 6 Connection coupling drain |
| 3 Emulsion inlet (G3/4) | 7 Connection power supply |
| 4 Emulsion outlet | 8 Connection coupling level measurement |

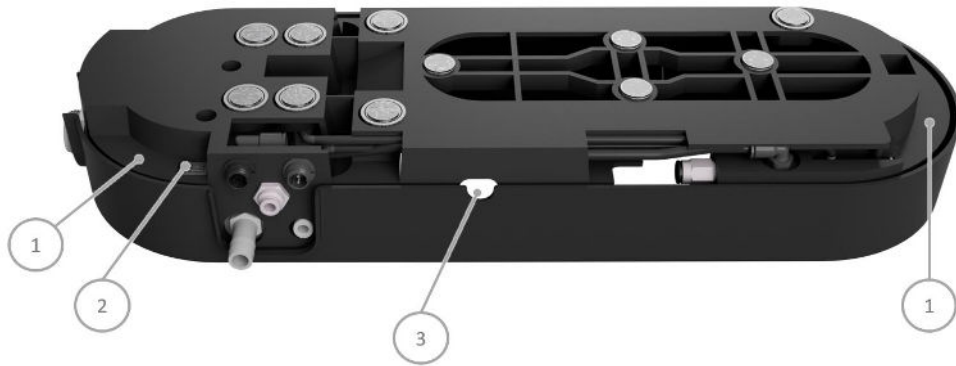

Fig. 6: Structure of the extender (rear view)

- 1 Recessed grip
- 2 Main switch
- 3 Ethernet cable breakthrough

3.7 Function and system description

The extender extends the functionality of the Liquidtool sensor with an automatic monitoring of the level of the cooling lubricant tank of a machine. The level is measured redundantly by means of differential pressure at the bottom of the tank as well as by means of an ultrasonic sensor on the lid of the tank. The measurement results are transmitted to the Liquidtool Manager and stored there.

In combination with a SmartFiller, a machine tool can be automatically filled with cooling lubricant based on the measured values.

3.8 LED status light

There are three LEDs on the front of the product. These flash as soon as the valves are open and cooling lubricant flows through the device.

The status of the product on is displayed via the LED on the Liquidtool sensor. For more information, please refer to our Liquidtool App.

Color	State	Description/meaning
White	lights up permanently	No internet connection
Green	lights up permanently	The device is ready for operation
Blue	lights up permanently	Device is paired via Bluetooth
Blue	flashing	The device is in Bluetooth pairing mode
Orange	lights up permanently	Warning
Red	lights up permanently	Fault/Error

Tab. 8 LED for status indication

3.9 Interfaces

The extender has the following interfaces:

- Power switch
- Status LED
- Plug connection (power supply)
- Plug connection (ultrasonic sensor)
- Inlet with filter
- Outlet
- Level measurement (differential pressure)
-

4 TRANSPORT, INSTALLATION AND STORAGE

4.1 Introductory notes on safety



Personnel qualification

The following personnel are authorized for "transport, installation and storage":

- Trained, instructed operating personnel



Important information for your safety

You are responsible!

In any case, the safety instructions in chapter "2 Basic safety instructions" and the locally applicable safety regulations must be observed and complied with.

Wear the required protective equipment (PPE).

SAFETY NOTE



Important information about transport

If the extender has already been used, you must decommission and clean it before transport. Follow the instructions in the respective chapter.

- Information on decommissioning can be found in chapter "7 Decommissioning" on page32 .
- Information on cleaning can be found in chapter "7.4 Cleaning" on page35 .

WARNING



Danger from strong magnets

The magnets cause strong, electromagnetic fields that can affect and interfere with electronic devices such as pacemakers. Malfunctioning pacemakers can cause death or serious injury to affected individuals.



- Persons with pacemakers must not be in the vicinity of the extender.
- Persons with pacemakers must not perform any activities with the extender.
- Regularly check the warning label on the extender or the machine tool. Replace damaged warning labels immediately.

4.2 Packing

The Extender is packed in cardboard boxes. Unpack all parts and dispose of the packaging in an environmentally friendly manner.

4.3 Transportation

Due to its light weight, you can carry the extender in its packaging to your installation site.

4.4 Delivery

4.4.1 Scope of delivery

Included in delivery are:

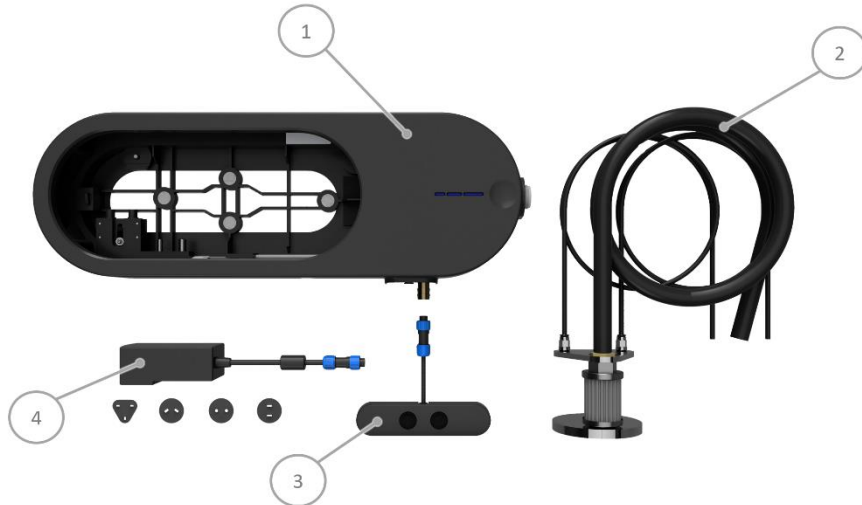

Fig. 7: Scope of delivery

- 1 1 Liquidtool Extender
- 2 3 hoses
(1x 12mm tracing, 1x 6mm measuring outlet, 1x 6mm level sensor)
- 3 1 Ultrasonic sensor
- 4 1 Power supply unit with plug adapter

4.4.2 Inspection for transport damage

Check the Extender for transport damage immediately after delivery to the installation site. If there is any transport damage, report it to the manufacturer immediately. It is recommended to document the transport damage with photos.

4.5 Download app

The extender is controlled and used via a specially developed app (Liquidtool Manager). The app can be downloaded and installed via smartphones.



To download the app, do the following:

1. Scan the QR code below with an appropriate app/camera on your smartphone.



LIQUIDTOOL App

<https://download.liquidtool.com/apps>

Fig. 8 QR code for downloading the app

- Your smartphone will ask you if you want to open the link.
2. Open the link.
 - This will take you to the extender manufacturer's website.
3. Follow the instructions on the screen.
 - ✓ The app download is complete. The app is ready to use.

4.6 Storage

If the extender is to be stored, the following criteria must be observed:

- Store in a dry and cool place
- up to 95% relative humidity
- Clean the extender before storage

5 COMMISSIONING

5.1 Introductory notes on safety



Personnel qualification

The following personnel are approved for "Commissioning":

- Trained, instructed operating personnel
- Specialists for special work on the machine tool, the cooling lubricant tank or the electrical system



Important information for your safety

You are responsible!

In any case, the safety instructions in chapter "2 Basic safety instructions" and the locally applicable safety regulations must be observed and complied with.

Wear the required protective equipment (PPE).

5.2 Lineup

Set-up diagram

The extender must be set up according to the set-up diagram. An installation example is shown schematically below.

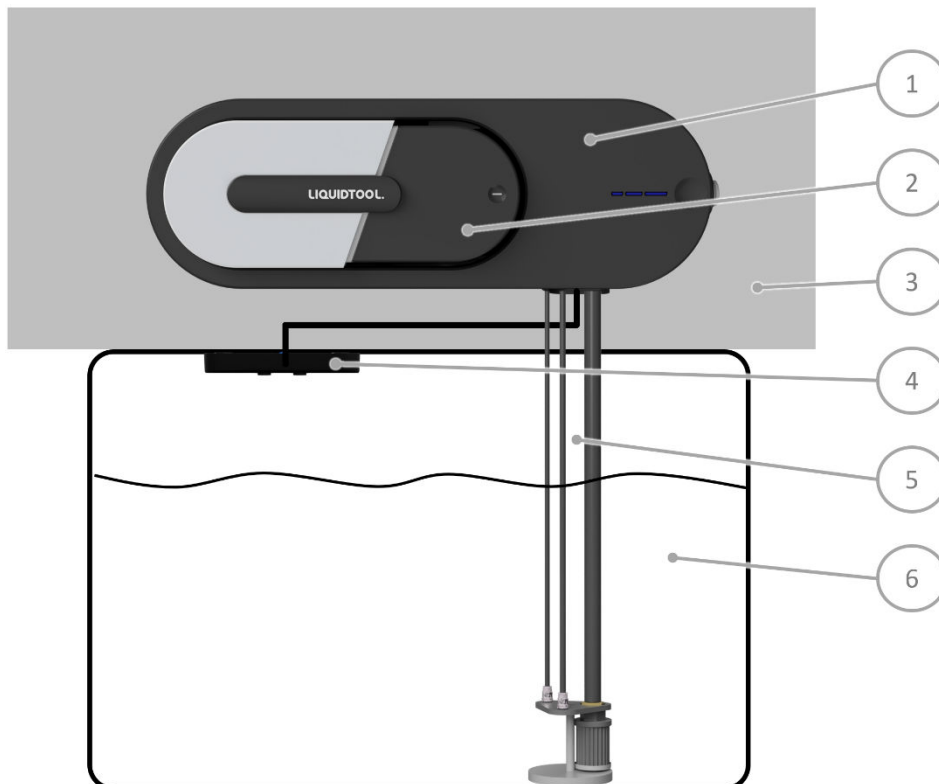

Fig. 9: Arrangement diagram

- 1 Extender
- 2 Sensor 01
- 3 Machine tool to which the extender is attached
- 4 Ultrasonic sensor
- 5 Connection lines
- 6 Cooling lubricant tank

Site

The following criteria are required of the Extender installation site and must be met:

- Near the cooling lubricant tank
- Do not install in potentially explosive atmospheres
- Ideally mount in a vertical/horizontal arrangement (do not mount the extender lying down, i.e. do not mount it with the magnets horizontal to the ground).
- Use a steel sheet at least 3 mm thick for mounting the device
- Do not mount the device higher than 2m above the ground
- Working range around the extender should be 1m
- Lay connections (cables and hose lines) between parts without tripping hazards

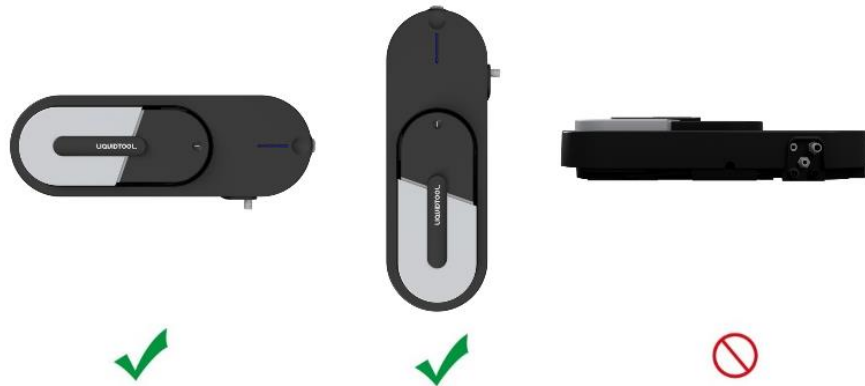

Fig. 10: Mounting positions

5.3 Notes on connecting the extender

The extender must be mounted and put into operation near the cooling lubricant tank of the machine tool. The extender is mounted via magnets on the back of the product. Accordingly, a magnetic surface is required. Direct mounting above the cooling lubricant tank is not mandatory, the connection cables are long enough for this. It is essential to observe the notes in the following chapters.

5.4

Connection

Prerequisite:

- The connection instructions have been read and understood
- There is 1 copy each of the individual warning and safety instructions



To connect the extender, proceed as follows:

1. Remove the sealing plugs (2) from the connection lines of the sensor. To do this, press the metal coupling rings (1) in the direction of the extender while pulling out the sealing plugs (2).
2. Remove the cover cap of the connector (3) for the serial connection.

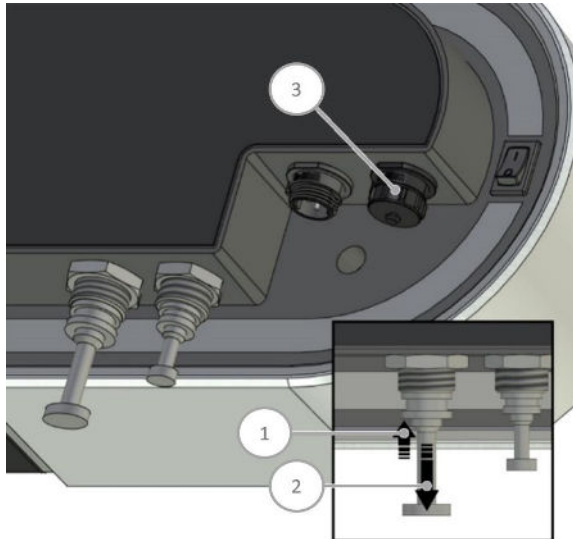

Fig. 11: Remove sealing plug and cover

3. Remove the cover of the extender, this is only attached by means of magnets and can simply be pulled off to the front. Put the cover aside.

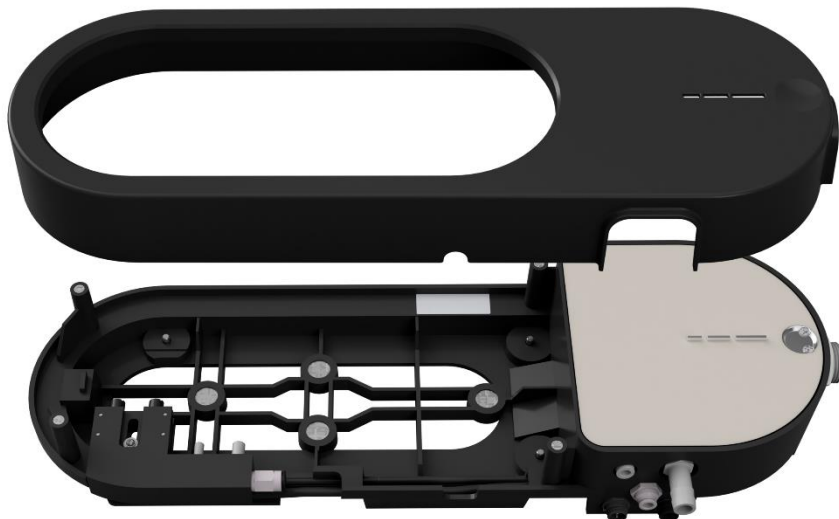

Fig. 12: Remove cover

4. Pull the two plug adapters outwards.

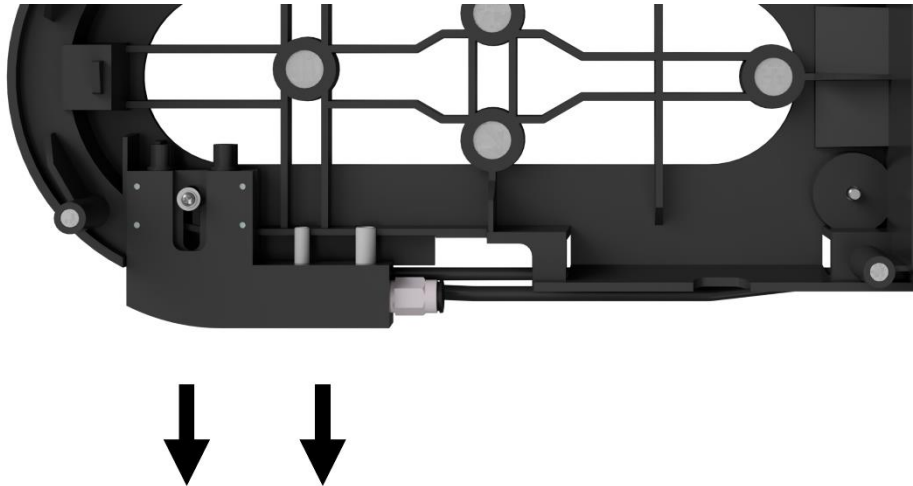

Fig. 13: Pull the plug adapter outward

5. **CAUTION!** Risk of crushing due to strong magnetic forces. The magnets of the sensor are strong and are quickly drawn to the extender. If fingers get between the magnets, they can be crushed. Hold the sensor so that your fingers only touch the side of the sensor.
6. Place the sensor in the extender, it will be centered automatically.



Fig. 14: Place sensor 01 in the extender

7. Carefully push the two plug adapters towards the sensor to ensure the connection of the two devices.
 - The left slider ensures the electrical connection, the right one the fluid connection
 - Make sure that the sliders are pushed in all the way, otherwise the cover cannot be mounted.

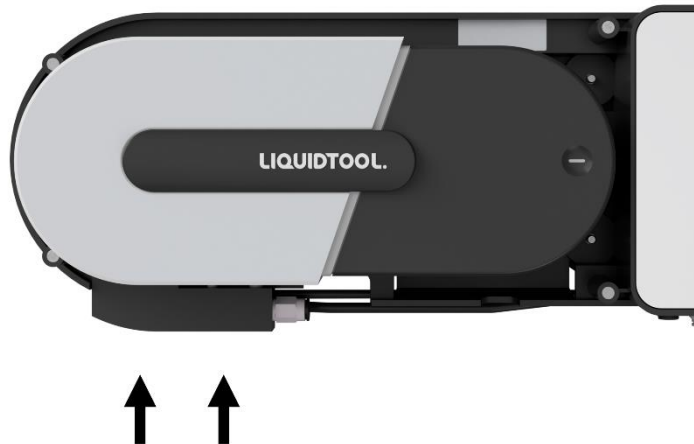

Fig. 15 Press the plug-in adapter in the direction of the sensor

8. Mount the cover on the extender

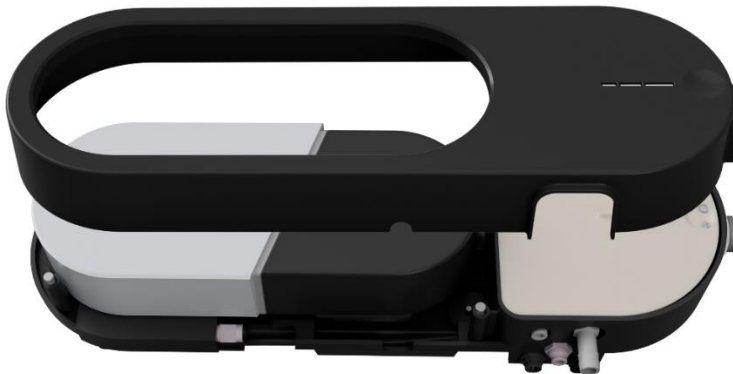

Fig. 16: Mount cover

9. Connect the supplied connection cables to the extender.
 - It is not necessary to secure the outlet hose (3), as it is not under pressure.



Fig. 17: Connecting the connection lines

10. Connect the supplied connection cables to the extender. Tighten the blue screw connection to secure them against unintentional disconnection.



Fig. 18: Connecting the connection cable

11. **⚠ CAUTION!** Risk of crushing due to strong magnetic forces. The magnets of the extender are strong and are quickly drawn to the metallic surface. If fingers get between the magnets and the metallic surface, they can be crushed. Hold the extender so that your fingers are in the recessed grip.
12. Guide the back of the extender to a magnetic surface near the cooling lubricant tank. We recommend mounting the extender above the cooling lubricant tank.

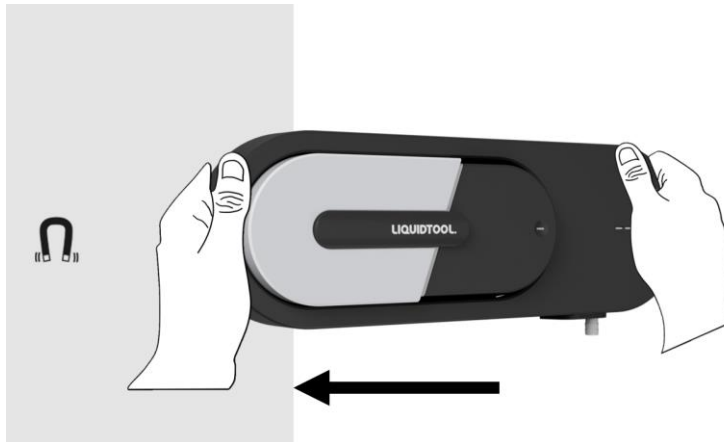

Fig. 19: Attach extender to surface

- You notice whether the magnets of the extender hold or not.
13. If the magnets do not hold, the surface is not suitable for attachment. Find another surface and repeat the previous step.
 - **⚠ CAUTION!** Risk of injury due to falling extender! Only release the extender slowly. This allows you to see whether it slips or moves. Reach for the extender if it slips or moves. In this way, you can prevent slight injuries to feet and damage to the Extender.
 - The magnets of the extender are strong and hold it in place.

14. Attach the warning and safety notices supplied with the sensor around the extender.



Fig. 20: Attaching warning labels (example)

15. Insert the connection lines into the cooling lubricant tank.

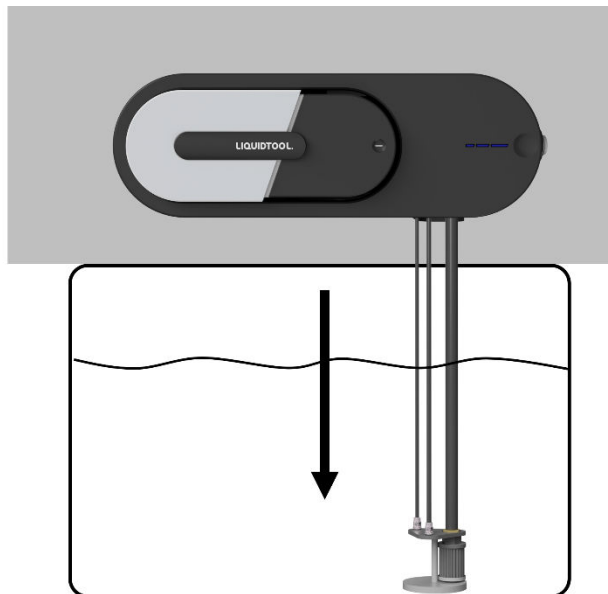

Fig. 21: Connection lines in the cooling lubricant tank

16. Check the length of the connection lines. There must be a maximum distance of 1.5 meters between the extender and the surface of the cooling lubricant!

17. Check the hose connection. This should be in contact with the tank bottom and have a stable stand. The suction filter must be completely surrounded by cooling lubricant.

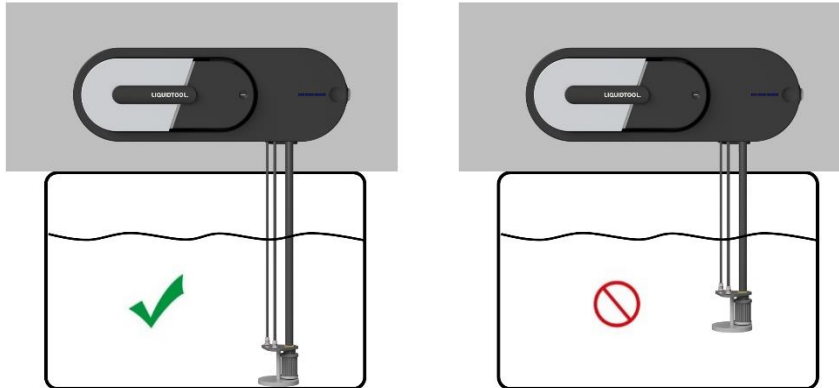

Fig. 22: Correctly laid connection lines

18. **⚠ CAUTION!** Risk of crushing due to strong magnetic forces. The magnets of the ultrasonic sensor are strong and are quickly drawn to the metallic surface. If fingers get between the magnets and the metallic surface, they can be crushed. Only hold the ultrasonic sensor on the side surfaces.
19. Place the ultrasonic sensor on the underside of the tank cap so that it has a clear line of sight to the surface of the cooling lubricant. The sensor is held in place by strong magnets.

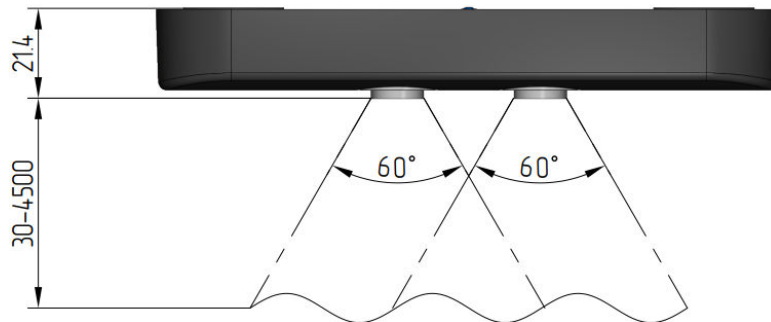

Fig. 23: Ultrasonic sensor

20. Connect the emulsion supply line to the extender.

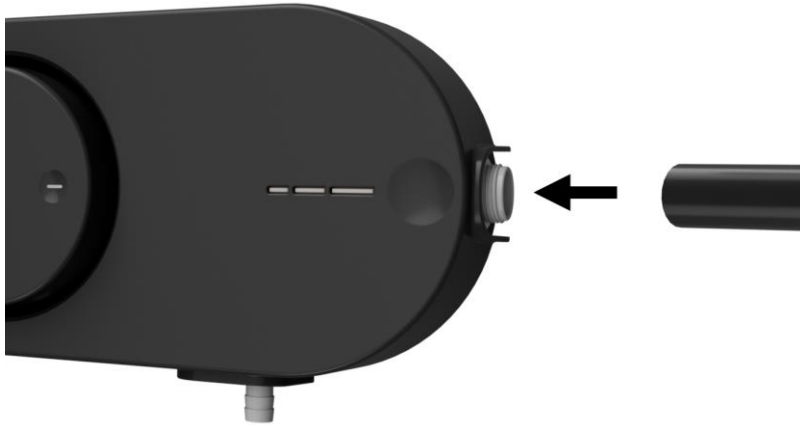

Fig. 24 Connecting the emulsion supply line

21. Insert the power plug into a suitable power outlet.

- ✓ The connection of the extender is complete. Now download the app.

6 OPERATION

6.1 Introductory notes on safety



Personnel qualification

The following personnel are approved for "operation":

- Trained, instructed operating personnel for the use of the extender within the scope of the intended use



Important information for your safety

You are responsible!

In any case, the safety instructions in chapter "2 Basic safety instructions" and the locally applicable safety regulations must be observed and complied with.

Wear the required protective equipment (PPE).

6.2 Switch on extender

Prerequisite:

- The extender is connected



To turn on the extender, proceed as follows:

22. Make sure that the extender is connected as described in chapter "5.5 Connection" on page 24 is connected.
23. Press the power switch on the back of the extender to the "I" position.
 - The status light on the front of the sensor will illuminate.
 - ✓ The extender is switched on.

6.3 Switch off extender

Prerequisite:

- The extender is switched on



To turn off the extender, proceed as follows:

24. Press the power switch on the back of the extender to the "O" position.
 - The illumination goes out.
 - The status light on the front panel flashes white and also goes out after a few seconds.
 - ✓ The extender is switched off.

6.4 Operation

The extender is operated via the associated app (Liquidtool Manager). Download the app as described in chapter "4.5 Downloading the app" on page 21

For more information on operation, see the app.

7 DECOMMISSIONING

7.1 Introductory notes on safety



Personnel qualification

The following personnel are authorized for "Decommissioning":

- Trained, instructed operating personnel for activities on the Extender.
- Specialists for special work on the machine tool, cooling lubricant tank or electrical system.
- All electrical work may only be carried out by instructed and authorized electricians



Important information for your safety

You are responsible!

In any case, the safety instructions in chapter "2 Basic safety instructions" and the locally applicable safety regulations must be observed and complied with.

Wear the required protective equipment (PPE).

⚠ CAUTION	
	<p>Risk of slipping due to leaking cooling lubricant</p> <p>After switching off the Extender, residues of the cooling lubricant remain in the lines and in the Extender itself. These can escape during decommissioning and collect in puddles on the floor. People step into these puddles, slip and injure themselves.</p> <ul style="list-style-type: none"> ➤ In case of leaking cooling lubricant, observe the manufacturer's data sheet. ➤ Remove puddles and leaked cooling lubricant immediately. ➤ Inform other people about the danger.

7.2 Dismantling

Prerequisite:

- The instructions for decommissioning have been read and understood
- The extender is switched off
- Wear the required protective equipment (PPE)
- Consider the data sheet of the cooling lubricant
- Absorbent paper



To dismantle the extender, proceed as follows:

25. Unplug the power cord from the wall outlet.
26. Place the plug within your field of view. This prevents third parties from reconnecting the extender.
27. **⚠ WARNING!** Danger of short circuit! Make sure that the plug of the power cable is not connected to a socket. If the electrically connected extender falls into the cooling lubricant tank, a short circuit may occur.
28. **⚠ WARNING!** Risk of injury due to contact with cooling lubricant. Although the Extender is switched off, residues of the cooling lubricants may still be present on or in lines or in the product. Direct contact of cooling lubricant with the skin can lead to illness and damage to health. Inhalation of the vapors or aerosols may cause irritation and respiratory diseases. Wear the required protective equipment and follow the instructions on the data sheet of the cooling lubricant.

29. Remove the hose line from the cooling lubricant tank and hold it over the tank so that the cooling lubricant can drip off.

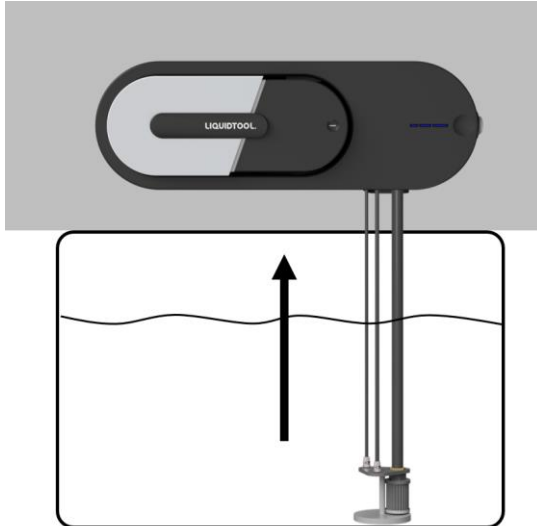

Fig. 25: Remove connection cable

30. Briefly press the status button on the sensor

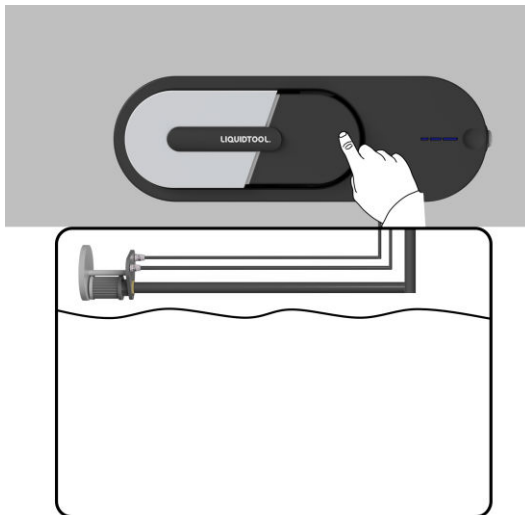

Fig. 26 Start manual measurement

- A manual measurement is started.
 - The extender is drained. After a few seconds, the pump should sound different due to dry running. This indicates that there is no more cooling lubricant in the extender.
31. Now also remove the outlet connection line from the cooling lubricant tank. Use the absorbent paper to collect escaping cooling lubricant.

32. Remove the ultrasonic sensor from the tank. It is only attached with magnets and can be pulled off with the appropriate force.
33. Pull the extender from the surface. It is only attached with magnets and can be pulled off with the appropriate force.

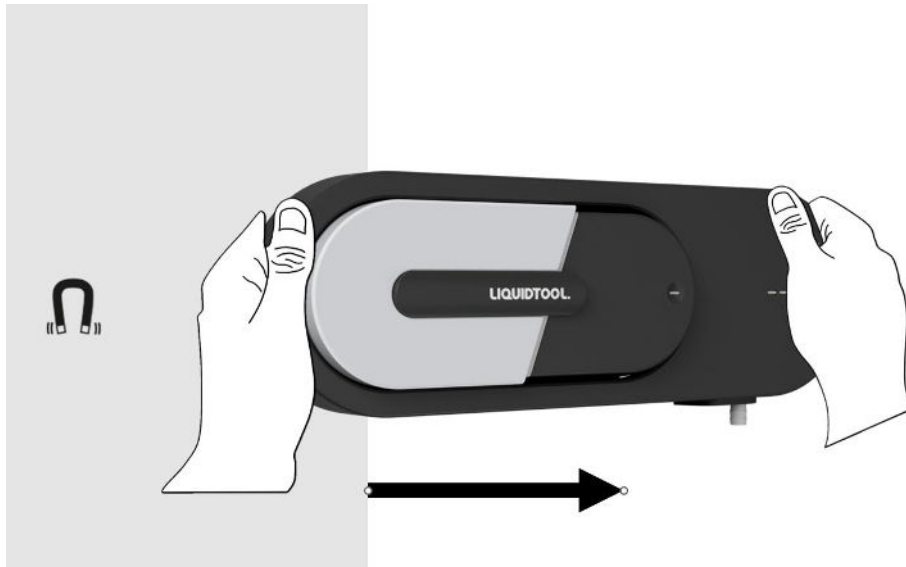



Fig. 27 Remove the extender from the surface

34.  **WARNING!** Risk of injury from escaping cooling lubricant. Residues of the cooling lubricant may still be present in the lines. These can leak out and pose a slip hazard. Remove leaked cooling lubricant immediately. Carry out the cleaning immediately. Wear the required protective equipment and follow the instructions on the data sheet of the cooling lubricant.
 - ✓ The extender is dismantled and can be cleaned.



Important information for dismantling

Due to the presence of residual cooling lubricant on the product, we recommend cleaning the product promptly. In this way, you can prevent the contamination of surfaces or other products by cooling lubricant. Dispose of the cooling lubricant according to the manufacturer's instructions.

7.3 Cleaning

Prerequisite:

- The extender is switched off
- Wear the required protective equipment (PPE)
- Consider the data sheet of the cooling lubricant

External cleaning of the extender:

- Clean the surfaces of the extender with a slightly damp cloth with soapy water
- Do not allow moisture to enter the extender during cleaning, therefore do not place or spray the extender in any cleaning liquid or water

8 SERVICE AND MAINTENANCE

Activity/area	Description	Interval
Checking the connection lines	on trip-free laying on leakage	Weekly Weekly
Safety and warning notices on the product or machine tool	check for completeness Replace if damaged	Monthly Monthly

Tab. 9: Maintenance schedule

Extender is maintenance-free

The product has been designed to be maintenance-free. No maintenance is required on the extender.



Important information about the measurement results

You are welcome to send us the extender. We will then check the extender and the measurement results and repair the product if necessary.

This gives you a long-lasting product and error-free and accurate measurement results.

8.1 Troubleshooting

If the extender does not work properly, there is a malfunction. Use the Messaging & Help system in our Liquidtool app to solve the problem.

9 DISPOSAL

9.1 Introductory notes on safety



Personnel qualification

The following personnel are approved for "disposal":

- Trained, instructed operating personnel
- All electrical work may only be carried out by instructed and authorized electricians



Important information for your safety

You are responsible!

In any case, the safety instructions in chapter "2 Basic safety instructions" and the locally applicable safety regulations must be observed and complied with.

Wear the required protective equipment (PPE).

9.2 Dismantling



Important information for dismantling

The Extender may only be disassembled by trained and authorized personnel.

9.3 Proper and environmentally compatible disposal



Important information

The aim is to dispose of the device in a proper and environmentally friendly manner. During individual maintenance work or when dismantling the Extender, waste materials may be produced which must be disposed of. Recommendations are given by the appropriate authorities.

The recommendations for the disposal of waste materials are derived from the regulations in force at the place and time of the preparation of these instructions. As the operator and user of the Extender, you have a duty to inform yourself about and act in accordance with the waste disposal regulations applicable to your region.

9.4 Disposal points

Please refer to your region for the appropriate disposal points.